

Low Profile APU for MBTs

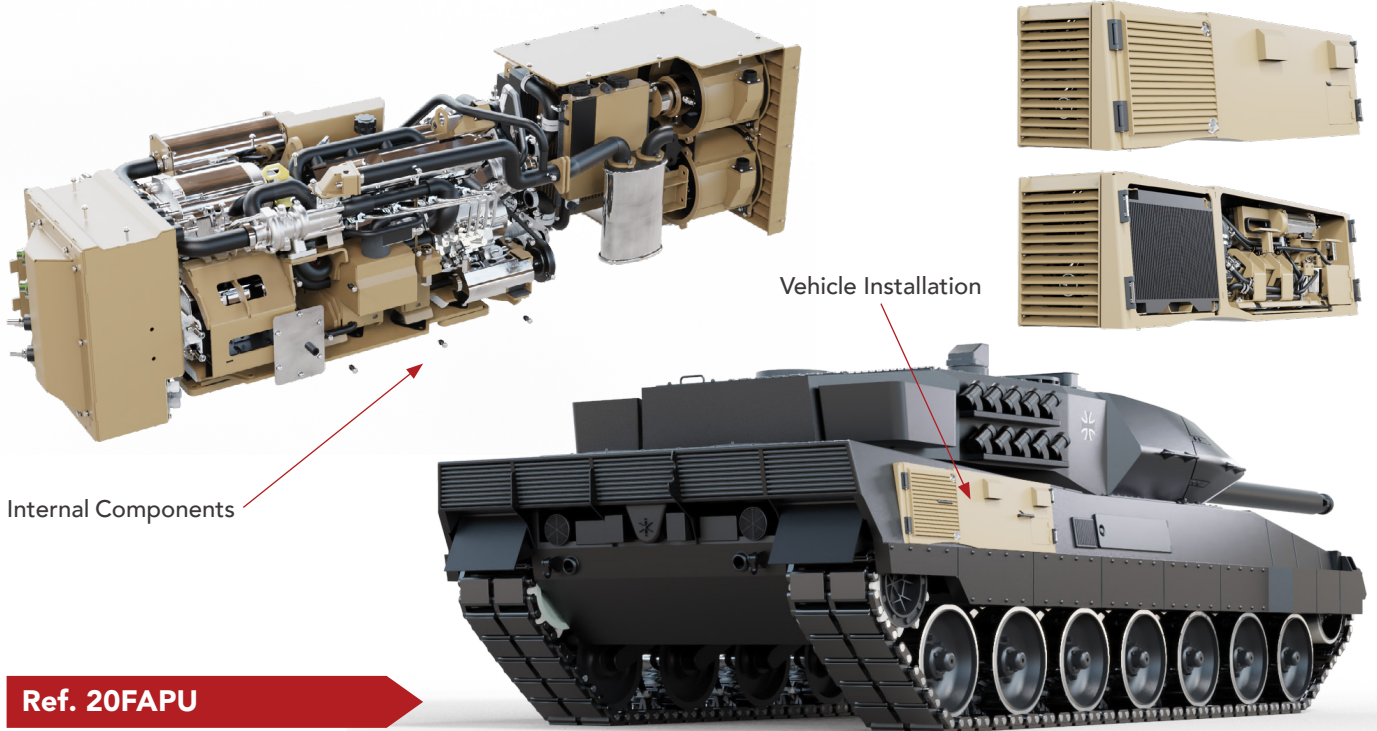

20kW AUXILIARY POWER UNIT (APU) WITH REDUCED HEIGHT FOR MAIN
BATTLE TANKS



Ref. 20FAPU

SPECIFICATION

PMG Output Power	20kW derated @ 3000 rpm in 49°C Ambient
Operating Envelope	-46°C to 49°C
Cold Start Requirement	-32°C without preparations, but up to -46°C with pre-heating preparations
28VDC Output Power	20kW; 715 A @ 0m and 49°C derated 17kW; 608 A @ 4500m and -10°C derated
Fuel	Fuel Supplied from Vehicle Fuel Tank
Batteries	Vehicle Batteries
Fault Finding	Bluetooth / HMI
Max overall dimensions	1800mm W x 535mm D x 500mm H
Start Up	Automatic from Remote HMI
Dust Filtration for combustion Air Intake (designed for 500mg/m³ sand & dust)	95% efficient cyclones with exhaust venturi + secondary pleated media dust filter
Load Control	Yes, by Regulation of PMG Excitation

FRONT, SIDE AND TOP VIEW

(Max Overall Dimensions 1,80 m wide x 0,54 m deep x 0.50 m high, weight 300kg)

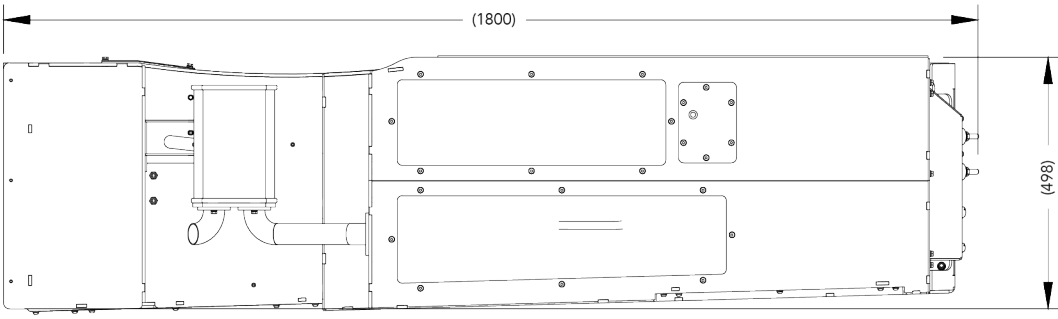

FRONT VIEW

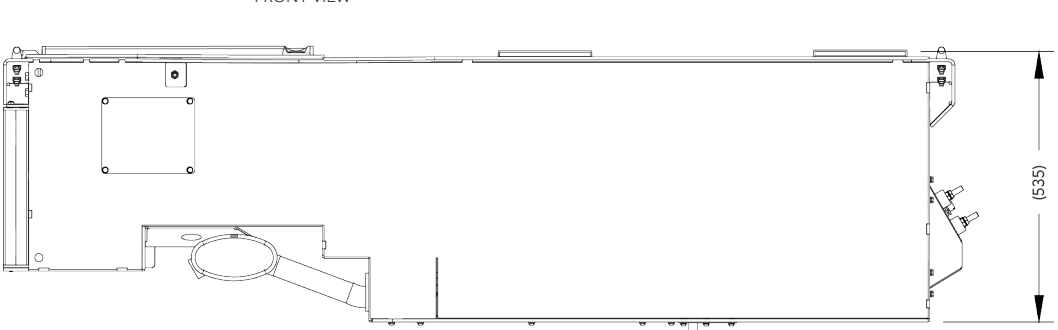

TOP VIEW

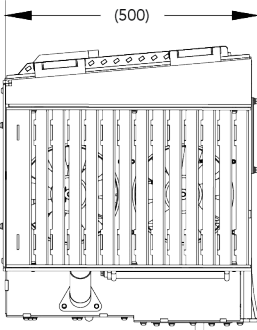

LEFT VIEW

ISOMETRIC VIEWS

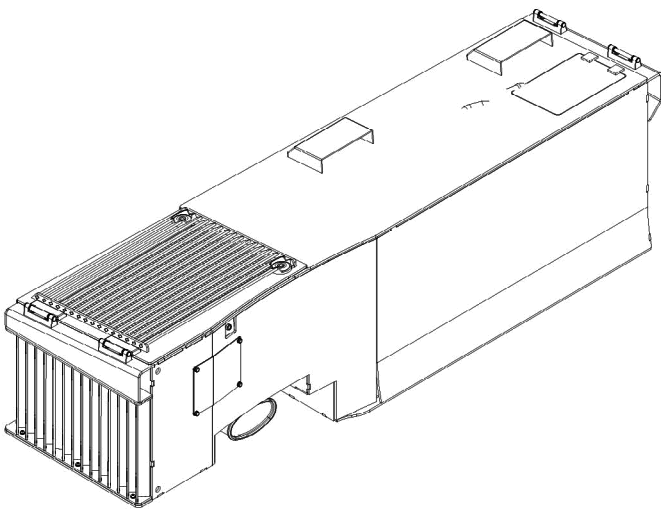

FRONT ISOMETRIC VIEW

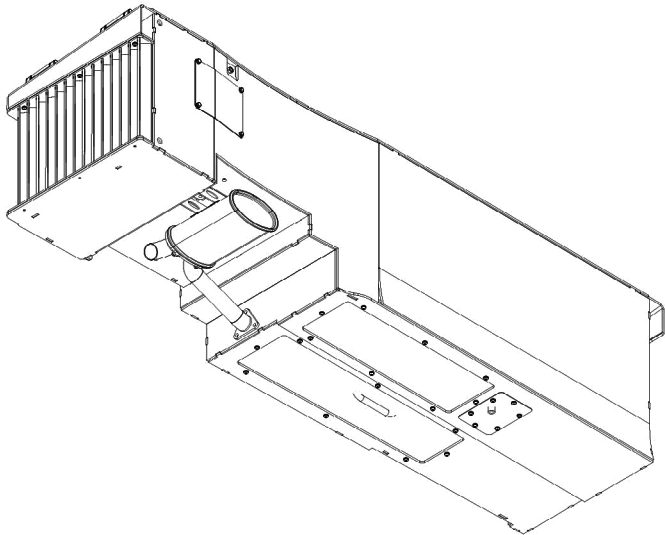

REAR ISOMETRIC VIEW

